

ITEM: E3SP

Sponsored Pet Waste Station

Sponsorship Kit Includes:

- A. 1 12"x 6" Custom Sponsor Sign (*Item E840*)
- B. 1 12"x18" Aluminum Sign (*Item E802*)
- C. 1 Dispenser Box (*Item E1*)
- D. 1 8-ft Steel Sign Post (*Item E18*)
- D. 1 10-gal Waste Receptacle with attached lid (*Item E10*)
- F. 4 Mounting Hardware Sets— each set includes 2 nuts, bolts and washers
- G. 80 Pet Waste Bags (*Item E41*)
- H. 50 Waste Receptacle Liners

Optional Tools Needed:

- Socket Driver or Adjustable Wrench
- Level
- Post Hole Driver

PET WASTE ELIMINATOR SUPERIOR STATIONS:

- ★ Lifetime Guarantee
- ★ Rust-Proof Construction
- ★ Universal Fit holds all bags on header cards or rolls

NEVER RUN OUT OF BAGS AGAIN!

Join our exclusive Refill Program and get FREE SHIPPING on every Bag Order!
Call to join today!

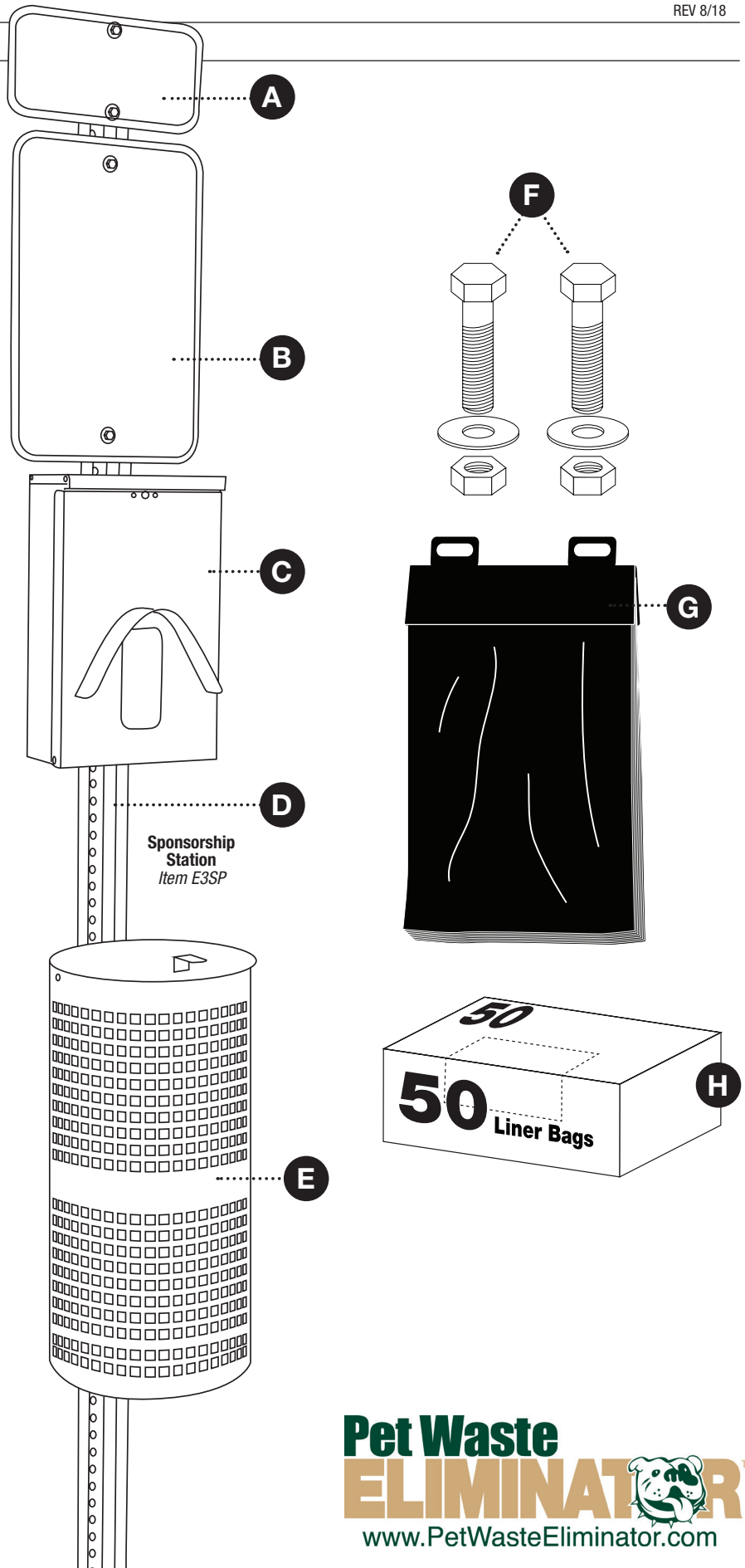

Pet Waste ELIMINATOR 
www.PetWasteEliminator.com

1. Pole Installation

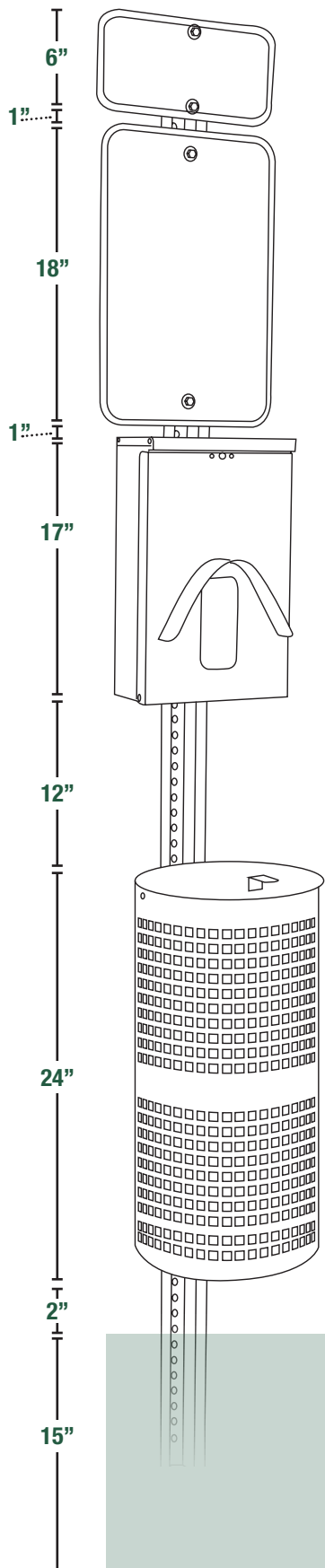

Using a post hole driver (not included), drive the sign post (D) approximately 12-15" into the ground. Make sure that the "hollow" or "recessed" side of the post is facing where you want the front of the unit to face. We recommend that the pole is no less than 12" underground to support the weight of the waste receptacle (E) properly. Use a level (not included) to ensure the pole is standing upright and will properly support the unit. Adjust if necessary.

2. Station Assembly

1. Using the first hardware set (F), secure the small sign (A) to the top of the steel post (D) with a bolt and washer at the top of the sign and another at the bottom. The washers should be next to the printed side (front) of the sign and the nuts are secured on the outside/back of the post. To ensure the best outcome, make sure the sign is flush with the top of the pole.
2. Using the second hardware set (F), secure the large sign (B) directly below the small sign (A) with a bolt and washer at the top of the sign and another at the bottom leaving about 1" in-between. The washers should be next to the printed side (front) of the sign and the nuts are secured on the outside/back of the post.
3. Using the third hardware set (F), attach the dispenser box (C) directly under the sign leaving about 1" in-between. Open the box, align the holes to the steel post and attach with the two bolts. The washers should be used on the inside of the box with the nuts secured to the outside/back of the post.
4. Using the final hardware set (F), secure the waste receptacle (E) to the steel post at the top and the bottom with the washers facing the inside of the waste can and the nuts on the outside/back of the post. Make sure that the receptacle is approximately 12 inches below the dispenser box to allow for the lid to be open and trash to be easily removed. This should leave your receptacle approximately 2 inches off the ground which will help prevent any damage to the station from bad weather conditions.

3. Station Preparation

1. Insert one waste liner (H) into the waste receptacle and fold over the rim. Open the dispenser box and insert up to 10 header cards of bags (G) onto the prongs inside the dispenser. Close the station, pull the top bag through the hole and you're all set!

Note: This dispenser fits all types of bags. If you are using boxed bags (Item E40), you will need to slip a converter (Item E22) onto the prongs inside the dispenser and insert the boxes into the converter.

Please contact us immediately if you have any missing or damaged items or need any additional assistance. Thank you.