

Budget Friendly BBQ Grill

Parts Include:

- A. Grill
- B. 5" Locking Pin
- C. 21" Top Post
- D. 21" Bottom Post

Suggested Tools for this installation:

- Hole Digger
- Pin Punch & Hammer
- Level

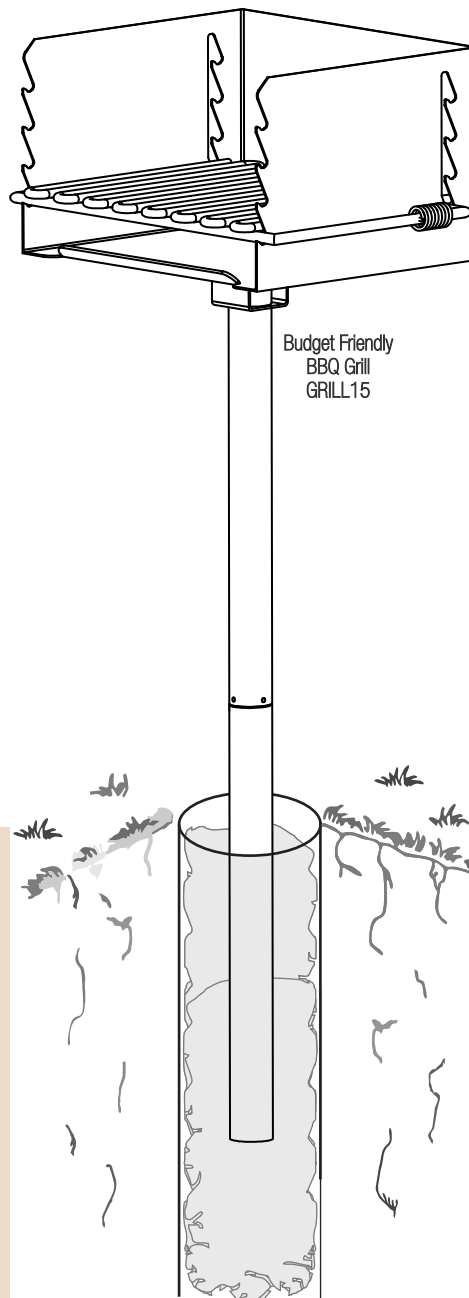
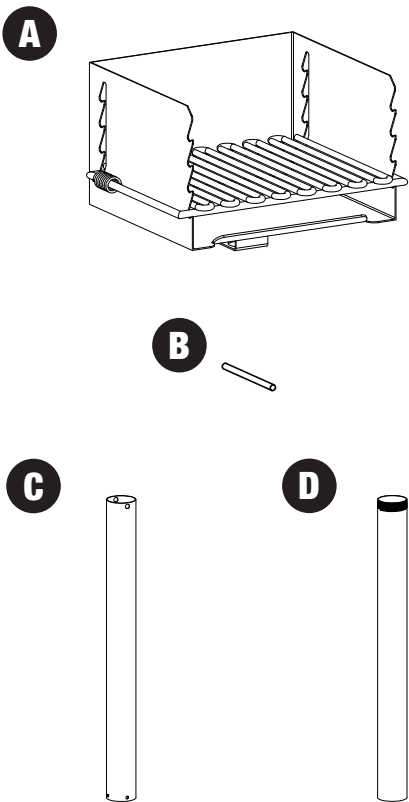

Grill Assembly:

1. Remove the plastic caps from both Posts. Screw both Posts together as shown on Figure 1.
2. Punch into each of the three shallow holes around the threaded section of the Top Post using a nail set, pin punch and hammer or similar tool.

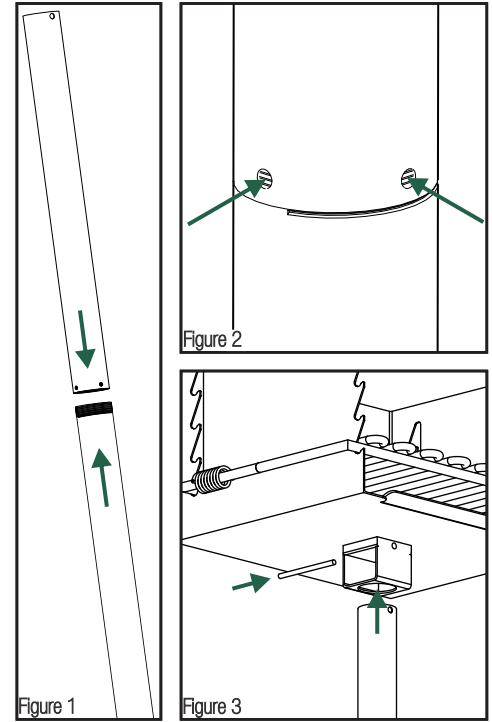

3. Make a hole on the desired installation location of 12" in diameter by 36" in depth. Check local codes to ensure a compliant installation. Fill hole with concrete.
4. Insert Posts into the concrete. Make sure the top end is 26" above ground level. Allow concrete to cure before continuing installation.
5. Install Grill on the Posts by sliding it in the swivel mechanism of the Grill. Lock Grill in place by aligning the holes on the front and back of the Grill swivel mechanism with the holes in the Post. Insert Locking Pin through the holes leaving an equal length protruding from each side.
6. Rotate Grill 360 degrees so the Locking pin is bent and drawn into the Swivel Mechanism.

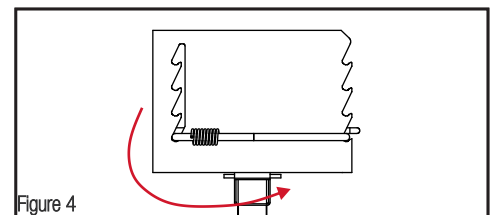

PET WASTE ELIMATOR'S BUDGET FRIENDLY BBQ GRILL:

- ★ Park quality construction features theft-proof swivel attachment!
- ★ Complies with fire code regulations!
- ★ Heavy-duty 1/8" thick steel construction!
- ★ 224 square inch grill area!

Grill Maintenance

Follow the guidelines below in order to maximize the useful lifetime of your grill and cooking grate:

1. Firebox: Regularly clean out all coal and/or wood ash from the firebox bottom. Ash combined with rainwater can accelerate the rusting process. The heat-resistant paint will last between one and two years depending on use frequency. If you notice signs of rust; wire brush off surface rust and spray or brush apply a new coat of non-toxic heat-resistant black enamel. Make sure to do the latter procedure only when the grill and firebox are cooled to air temperature. If the grill is not used for extended periods of time, rotate the firebox occasionally to break any rust bond.

Warning: do not build extremely hot, large fires or maintain them for extended periods of time to prevent firebox warping. Grill is reinforced to resist warping but overbuilt fires are outside the design parameters and intended purpose of their use.

2. Cooking Grate: The cooking grate should be seasoned before grilling directly on the steel grate. Season the grate by gradually burning the heat resistant, non-toxic paint off the grate bars as the grill is used. As the grate is heated, use a wire brush to both clean the grate and remove any paint chips. Use aluminum foil to cover the grate bars or use a pan to cook food until the grate is seasoned. Once the grate is seasoned use a wire brush to remove rust and left over food particles before each use. Heat the grate before use by keeping it close to the coals then raise the grate and scrape it clean. The best seasoned grate has the original finish burned off and has a good coating of grease on the steel grate bars.

Warning: Do not re-paint the cooking grate. Grease from cooking meat will usually keep rust at bay and a good wire brushing after the grate is hot also helps. If there is still rust on the grate, use aluminum foil between your food and the grate. Additionally, a cooking oil may be applied before each use. Be sure to apply cooking oil before starting the fire.

Local environment and climatic conditions may require more frequent maintenance.



Warning: This product can expose you to chemicals including carbon monoxide which are known to the State of California to cause cancer, or birth defects or other reproductive harm. For more information go to www.P65Warnings.ca.gov